

## UNIT – VI

### SYSTEMS OF CONVEYANCE OF WATER:

- The water may be supplied either continuously for all the 24 hours of the day or may be supplied intermittently only for the peak periods during morning and evening.
- The intermittent supply system may sometimes lead to some saving in water consumption due to losses occurring for lesser time and more vigilant use of water by consumers. This method may, therefore, be adopted at places where there is a shortage of water at the source.
- However, the intermittent system should not be continued as a long term policy, and be replaced by the continuous system at the earliest opportunity, because of the inherent limitations of this system.

### The limitations or disadvantages of the intermittent system are:

1. In this system, water is generally stored by consumers in tanks, drums, utensils etc., for non – supply hours. This water is thrown away by them even if unutilised as soon as the fresh supply is restored, this increases the wastage of water.
2. People have tendency to keep the taps open during non – supply hours, so they may come to know if the supply is restored. Many times, water goes on flowing unattended even after the supply is restored, thus resulting in the wastage of water.
3. Intermittent system of supplies do not cover the risks during non-supply periods. Any fire break-out during such periods may bring disaster and immense damage to life and property.
4. This system causes great inconvenience to consumers, keeping them on their toes for receiving and collecting water as soon as the supply is restored.
5. Since in this system, the supply of water for the whole day has to be pumped during 6 to 8 hours only, it will necessitate the use of bigger sized distribution mains, if the water is supplied to the whole town at the same time.
6. When the supply of water is stopped and the water from the pipe is drawn off, a partial vacuum may be created in the pipe. This will induce suction through the leaky joints, and if the pipes are surrounded by dirt on the ground, the same may get into the pipes. This will contaminate the initial supplies as and when the supply is restored.
7. A number of air valves and sluice valves are required to be fitted in the distribution system. These valves will have to be operated daily while opening or closing the

supply. This will necessitate additional watch and ward staff and high maintenance cost.

## **PIPE MATERIALS:**

### **1. Cast Iron Pipes:**

- Cast iron pipes are widely used for city water supplies.
- They are sufficiently resistant to corrosion and may last for 100 years.
- They are generally manufactured in length of about 3.5 m, but may be manufactured up to 6m, may be on special orders.
- Cast iron pipe can be manufactured by two methods.
  1. Ordinary sand moulding
  2. Centrifugal process
- Pipe cast in horizontal position by ordinary sand moulding are called Mc Wane' pipes. while those cast vertically are called Pit cast pipes.
- Horizontal cast pipes are 100 percent stronger in tension and 50 percent stronger in rupture than vertically cast iron pipes.
- Centrifugally cast iron pipes are made either in sand or metallic moulds. The former are called Sand spun pipe and the latter are called Delavaud pipes.
- The spun iron pipes are denser and tougher than the pipe, moulded by ordinary methods.
- In spun iron casting in metallic moulds, the molten metal is applied to the interior of a water cooled cylindrical metal mould which is rotated rapidly.
- Spun iron pipes in India are available in 3 classes.
  1. Class LA
  2. Class A
  3. Class B
- To protect these pipes bituminous linings are provided.

### **The advantages of cast iron pipes are:**

1. Moderate in cost
2. Easy to join
3. Strong and durable
4. Corrosion resistant
5. Long life upto 100 years
6. Service connections can be easily made



**Fig: Cast Iron Pipes**

**The disadvantages of cast iron pipes are:**

1. Water carrying capacity decreases with time as the value of friction factor increases.
2. They cannot be used for high pressures. Generally not used for measures above 700 kN/sq.m.
3. When large, they are very heavy and uneconomical.
4. They are likely to break during transportation or while making connections.

**2. Steel Pipes:**

- Steel pipes of varying thickness for with standing different pressures are generally bent and welded so as to manufacture steel pipes.
- Welded pipes are smoother and stronger than riveted pipes.
- Steel is strong in tension, larger diameter pipes can be made  $> 6m$ .
- Steel pipes used as raw water trunk mains, inverted syphons, where pressures are high and sizes larger.
- Difficulty in making connections, rarely used in distribution mains, mostly cast iron pipes are used.
- Galvanized steel pipes with corrugations are much stronger than ordinary pipes.
- 20 cm to 2 m in diameter are generally available.



**Fig: Steel Pipes**

**Disadvantages:**

1. Not adopted to withstand external loads of backfill, traffic etc.
2. Partial vacuum caused by emptying of pipe may cause collapse or distortions, if not designed properly.
3. Thinner walls and greater susceptibility to corrosion are likely to cause high maintenance charges and shortened life.
4. Average life 25 to 50 years.

**3. Cement Concrete Pipes:**

- Plain CC pipes are manufactured in small sizes (i.e., 0.6 m dia.)
- If reinforced, size may be extended up to 1.8m dia. and may up to 4.5 m on special orders.
- Can be manufactured at site (cast in situ) or at factories ( precast pipes).

RCC pipes may be manufactured in 3 ways:

1. Pipes having bar and mesh reinforcement and concrete – ordinary methods.
  2. Pipes made by rotating the mould about axis. Centrifugal force throws off the concrete – centrifugal type.
  3. Lining thin cylindrical steel shells both internally and externally with rich CC- more stronger – more water tight than other 2 types.
- RCC pipes are generally with a mix proportion of 1:2:2 CC with max size of aggregate 6 mm.

- With the advancement of pre stressed concrete, pre stressed concrete pipes are now in markets.

**Advantages of RCC pipes are:**

- They resist external compressive loads.
- Not corroded from inside from normal potable water and from outside by ordinary soils.
- They are strong and their useful life is 75 years.
- Easy to construct either at site or at factories with local ingredients.
- Coefficient of expansion is low, expansion joints may not be needed.
- If laid under water, empty pipes do not float because of their heavy weights.



**Fig: RCC Pipes**

**Disadvantages of RCC pipes are:**

1. Corrode by ground waters, due to presence of acids, alkalis or sulphur compounds.
2. Difficult to repair.
3. Cannot withstand very high pressures.
4. Heavy and bulky, hence difficult to transport.

**4. Hume steel pipes:**

- Hume steel pipes are RCC spun pipes patented under this name.
- Thin steel shell coated from inside with cement mortar lining, thickness of inside coating varies from 1.2 to 3.75cm, – depending upon the size of pipe.
- Outside coating varies from 2.5cm for 1 m dia. and 3.75cm for larger dia. Pipes.

### 5. Vitrified clay pipes:

- Not used as pressure pipes for carrying water, but used for carrying sewage and drainage at partial depths.
- Free from corrosion and provide smooth hydraulically efficient surface.
- Not used as pressure types because clay is very weak in tension.
- Clay pipes of normally made to a length of 0.6 to 1.2m.

### 6. Asbestos pipes:

- Asbestos, silica and cement are converted under pressure to a dense homogeneous material possessing high strength called asbestos cement.
- Generally 10 to 90 cm dia. and 4m length pipes are manufactured.
- These pipes are generally made in 4 different grades to withstand a pressure of 350 kN/m<sup>2</sup> to 1400 kN/m<sup>2</sup>.

### Advantages of asbestos pipes:

1. They are light and hence easy to transport.
2. They can be easily assembled without skilled labour.
3. They are highly resistant to corrosion, suitable for small distribution pipes.
4. They are highly flexible and may permit as much as 12° deflection in laying them around curves.
5. Expansion joints are not required as the coefficient of expansion is low and the joints are also flexible.



**Fig: Asbestos Pipes**

### **Disadvantages of asbestos pipes:**

1. They are costly.
2. These pipes do not have much strength and are brittle and soft.
3. The rubber joint seals may deteriorate if exposed to gasoline or other petroleum products, and hence cannot be used for transporting petroleum products.

### **HYDRAULICS OF FLOW IN PIPES:**

#### **Energy Losses in Pipes:**

When a fluid flows through a pipe, certain resistance is offered to the flowing fluid, which results in causing a loss of energy. The various energy losses in pipes may be classified as:

- (i) Major losses.
- (ii) Minor losses.

The major loss of energy, as a fluid flows through a pipe, is caused by friction. It may be computed by Darcy-Weisbach equation as indicated earlier. The loss of energy due to friction is classified as a major loss because in the case of long pipelines it is usually much more than the loss of energy incurred by other causes.

The minor losses of energy are those which are caused on account of the change in the velocity of flowing fluid (either in magnitude or direction). In case of long pipes these losses are usually quite **small** as compared with the loss of energy due to friction and hence these are termed 'minor losses' which may even be neglected without serious error. However, in short pipes these losses may sometimes outweigh the friction loss. Some of the losses of energy which may be caused due to the change of velocity are indicated below:

- (a) Loss of energy due to sudden enlargement,

$$h_L = (V_1 - V_2)^2 / 2g$$

- (b) Loss of energy due to sudden contraction,

$$h_L = 0.5 V^2 / 2g$$

- (c) Loss of energy at the entrance to a pipe,

$$h_L = 0.5 V^2 / 2g$$

- (d) Loss of energy at the exit from a pipe,

$$h_L = V^2 / 2g$$

(e) Loss of energy due to gradual contraction or enlargement,

$$h_L = k (V_1 - V_2)^2 / 2g$$

(f) Loss of energy in bends,

$$h_L = k V^2 / 2g$$

(g) Loss of energy in various pipe fittings,

$$h_L = k V^2 / 2g$$

### Equation for Head Loss in Pipes Due to Friction—Darcy-Weisbach Equation:

Consider a horizontal pipe of cross-sectional area  $A$  carrying a fluid with a mean velocity  $V$ . Let 1 and 2 be the two sections of the pipe  $L$  distance apart where let the intensities of pressure be  $p_1$  and  $p_2$  respectively. By applying Bernoulli's equation between the sections 1 and 2, we obtain

$$\frac{p_1}{\gamma} + \frac{V_1^2}{2g} + Z_1 = \frac{p_2}{\gamma} + \frac{V_2^2}{2g} + Z_2 + h_f$$

Where  $V_1 = V_2 = V$  and  $Z_1 = Z_2$

$$\text{Loss of head} = h_f = \frac{p_1}{\gamma} - \frac{p_2}{\gamma}$$

i.e., the pressure intensity will be reduced by the frictional resistance in the direction of flow and the difference of pressure heads between any two sections is equal to the loss of head due to friction between these sections. Further let  $f'$  be the frictional resistance per unit area at unit velocity, then

$$\text{Frictional resistance} = f' \times \text{area} \times V^n = f' \times PL \times V^n$$

where  $P$  is the wetted perimeter of the pipe.

The pressure forces at the sections 1 and 2 are  $(p_1 A)$  and  $(p_2 A)$  respectively. Thus resolving all the forces horizontally, we have

$$p_1 A = p_2 A + \text{frictional resistance}$$

$$(p_1 - p_2) A = f' PL \times V^n$$



$$(p_1 - p_2) = f' (P/A) L x V^n$$

Dividing both sides by the specific weight  $\gamma$  of the flowing fluid

$$(p_1 - p_2) / \gamma = (f' / \gamma) (P/A) L x V^n$$

$$h_f = (f' / \gamma) (P/A) L x V^n$$

The ratio of the cross-sectional area of the flow (wetted area) to the perimeter in contact with the fluid (wetted perimeter) i.e.,  $(A/P)$  is called hydraulic mean depth (H.M.D.) or hydraulic radius and it is represented by  $m$  or  $R$ .

$$h_f = (f' / \gamma) (L x V^n) / m$$

For pipe running full

$$m = (A/P) = D/4$$

Substituting this in the equation for  $h_f$  and assuming  $n=2$

$$h_f = (4f' / \gamma) (L x V^2) / D$$

### **Siphon:**

A siphon is a long bent pipe which is used to carry water from a reservoir at a higher elevation to another reservoir at a lower elevation when the two reservoirs are separated by a hill or high level ground in between as shown in Fig. Since the siphon is laid over the hill or the high level ground, for some length from the entrance section it will rise above the water surface in the upper (or supply) reservoir, and then for the remaining length it will drop down to be connected to the lower reservoir.

The rising portion of the siphon is known as the 'inlet leg (or inlet limb)', the highest point is known as summit and the portion between the summit and the lower reservoir is known as outlet leg (or outlet limb). As may be seen in Fig. the inlet leg (or inlet limb) of a siphon is usually smaller than the outlet leg (or outlet limb). As the siphon is also a long pipe, the loss of head due to friction will be very large and hence the other minor losses may be neglected. Further the length of the siphon may be taken as the length of its horizontal projection. Hence the hydraulic grade line and the energy grade line (or total energy line) for a siphon, as shown in Fig.2.1 may also be obtained in the same manner as in the case of an ordinary long pipe.

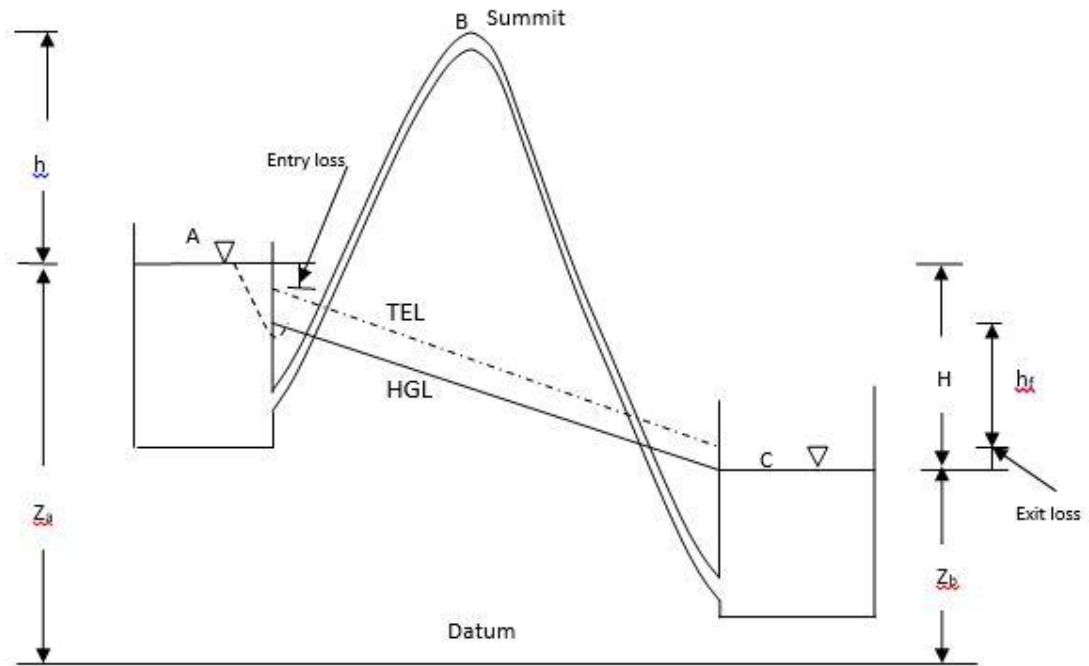


Fig. 2.1 Siphon

It will be seen from Fig. 2.1, that the hydraulic grade line cuts the siphon at points C and D, so that some portion of the siphon is above the hydraulic grade line. The vertical distance between the hydraulic grade line and the pipe centre line represents the pressure at any section. If the hydraulic grade line is above the centre line of the pipe then the pressure is above atmospheric; and if the hydraulic grade line is below the centre line of the pipe, the pressure is negative or below atmospheric.

Thus for the portion of the siphon below points C and D the pressure will be above atmospheric and at points C and D the pressure of the water flowing in the siphon is equal to atmospheric pressure. For the portion of the siphon between C and D the pressure will be below atmospheric. As the highest point of the siphon above the hydraulic grade line is the summit S, the water pressure at this point is the least. Further as the vertical distance between the summit of the siphon and the hydraulic grade line increases, the water pressure at this point reduces. Theoretically this pressure may be reduced to - 10.3 m of water (if the atmospheric pressure is 10.3 m of water) or absolute vacuum, because this limit would correspond to a perfect vacuum and the flow would stop. However, in practice if the pressure is reduced to about 2.5 m of water absolute or 7.8 m of water vacuum the dissolved air or other gases would come out of the solution and collect at the summit of the siphon in

sufficient quantity to form an air-lock, which will obstruct the continuity of the flow, (or the flow will completely stop).

A similar trouble may also be caused by the formation of the water vapour in the region of low pressure. Therefore the siphon should be laid so that no section of the pipe will be more than 7.8 m above the hydraulic grade line at the section. Moreover, in order to limit the reduction of the pressure at the summit the length of the inlet leg of the siphon is also required to be limited. This is so because as indicated below, if the inlet leg is very long a considerable loss of head due to friction is caused, resulting in further reduction of the pressure at the summit.

## PIPES IN SERIES AND PARALLEL

In many pipe systems there is more than one pipe involved. The governing mechanisms for the flow in multiple pipe systems are the same as for the single pipe systems.

### Pipes in Series



The indicated pipe system has a steady flow rate  $Q$  through three pipes with diameters  $D_1$ ,  $D_2$ , &  $D_3$ . Two important rules apply to this problem.

1. The flow rate is the same through each pipe section.

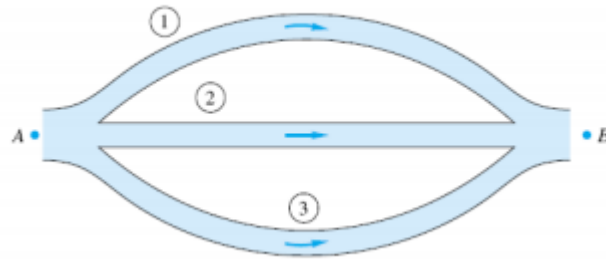
$$Q_1 = Q_2 = Q_3 = Q$$

2. The total frictional head loss is the sum of the head losses through the various sections.

$$h_{f,a-b} = h_{f,1} + h_{f,2} + h_{f,3}$$

$$h_{f,a-b} = \left( f \frac{L}{D} + \sum K_i \right)_{D_1} \frac{V_1^2}{2g} + \left( f \frac{L}{D} + \sum K_i \right)_{D_2} \frac{V_2^2}{2g} + \left( f \frac{L}{D} + \sum K_i \right)_{D_3} \frac{V_3^2}{2g}$$

### 2.6.2 Pipes in Parallel



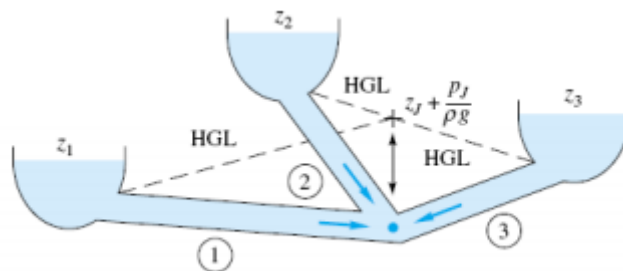
The indicated pipe system has a steady flow rate  $Q_1$ ,  $Q_2$ ,  $Q_3$  through three pipes with diameters  $D_1$ ,  $D_2$ , &  $D_3$ . Two important rules apply to this problem.

$$\Delta h_{A \rightarrow B} = \Delta h_1 = \Delta h_2 = \Delta h_3$$

$$Q = Q_1 + Q_2 + Q_3$$

### BRANCHED PIPES

Consider the third example of a three-reservoir pipe junction as shown in the figure .  
If all flows are considered positive toward the junction, then



$$Q_1 + Q_2 + Q_3 = 0$$

which obviously implies that one or two of the flows must be away from the junction. The pressure must change through each pipe so as to give the same static pressure  $p_J$  at the junction. In other words, let the HGL at the junction have the elevation.

$$h_J = z_J + \frac{p_J}{\rho g}$$

$$\Delta h_1 = \frac{V_1^2}{2g} \frac{f_1 L_1}{d_1} = z_1 - h_J$$

$$\Delta h_2 = \frac{V_2^2}{2g} \frac{f_2 L_2}{d_2} = z_2 - h_J$$

$$\Delta h_3 = \frac{V_3^2}{2g} \frac{f_3 L_3}{d_3} = z_3 - h_J$$

## **WATER DISTRIBUTION:**

### **REQUIREMENTS OF WATER DISTRIBUTION:**

The various requirements for proper functioning of a distribution system are:

1. It should be capable of supplying water at all the intended places within the city with a reasonably sufficient pressure head.
2. It should be capable of supplying the requisite amount of water for fire fighting during such needs.
3. It should be cheap with the least capital construction cost. The economy and the cost of installing the distribution system is a very important factor, because the distribution system is the most costly item in the entire water supply scheme.
4. It should be simple and easy to operate and repair, thereby keeping the RMO cost and troubles to the minimum.
5. It should be safe against any future pollution of water. This aim may be achieved by keeping the water pipe lines above and away from the sewerage and drainage.
6. It should be safe as not to cause the failure of the pipe lines by bursting etc.
7. It should be fairly water-tight, as to keep the losses due to leakage to the minimum.

### **SERVICE RESERVOIRS:**

Distribution reservoirs, also called service reservoirs, are the storage reservoirs, which store the treated water for supplying water during emergencies (such as during fires, repairs, etc.) and also to help in absorbing the hourly fluctuations in the normal water demand.

#### **Functions of Distribution Reservoirs:**

1. To absorb the hourly variations in demand.
2. To maintain constant pressure in the distribution mains.
3. Water stored can be supplied during emergencies.

#### **Location and Height of Distribution Reservoirs:**

- Should be located as close as possible to the centre of demand.

- Water level in the reservoir must be at a sufficient elevation to permit gravity flow at an adequate pressure.

### **Types of Reservoirs:**

1. Underground reservoirs.
2. Small ground level reservoirs.
3. Large ground level reservoirs.
4. Overhead tanks.

### **Storage Capacity of Distribution Reservoirs:**

The total storage capacity of a distribution reservoir is the summation of:

**1. Balancing Storage:** The quantity of water required to be stored in the reservoir for equalising or balancing fluctuating demand against constant supply is known as the balancing storage (or equalising or operating storage). The balance storage can be worked out by **mass curve method**.

**2. Breakdown Storage:** The breakdown storage or often called emergency storage is the storage preserved in order to tide over the emergencies posed by the failure of pumps, electricity, or any other mechanism driving the pumps. A value of about 25% of the total storage capacity of reservoirs, or 1.5 to 2 times of the average hourly supply, may be considered as enough provision for accounting this storage.

**3. Fire Storage:** The third component of the total reservoir storage is the fire storage. This provision takes care of the requirements of water for extinguishing fires. A provision of 1 to 4 per person per day is sufficient to meet the requirement.

The total reservoir storage can finally be worked out by adding all the three storages.

### **LAY OUT OF DISTRIBUTION SYSTEM:**

1. Dead end system
2. Grid iron system or interlaced or reticulation system
3. Ring system
4. Radial system

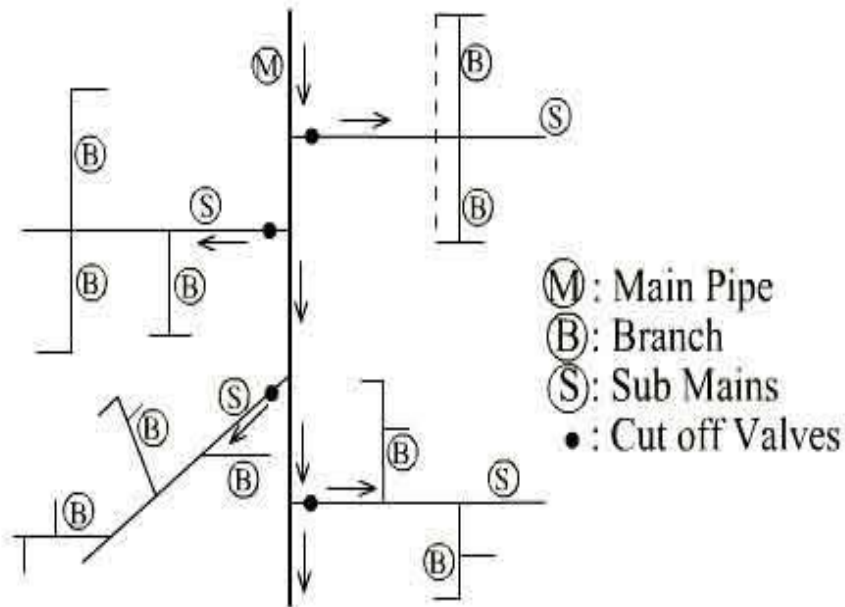
#### **1. Dead End System:**

- May be adopted for older towns, which have been developed in a haphazard manner and without properly planned roads.
- Suitable for – which expand irregularly

### Advantages:

1. Distribution network can be solved easily – easily to calculate discharge easily.
2. Lesser sluice valves are required.
3. Shorter pipe lengths are needed, so laying of pipes is easy.
4. Cheap, simple, extended easily.

### *Dead End or Tree System*



**Fig: Dead End System**

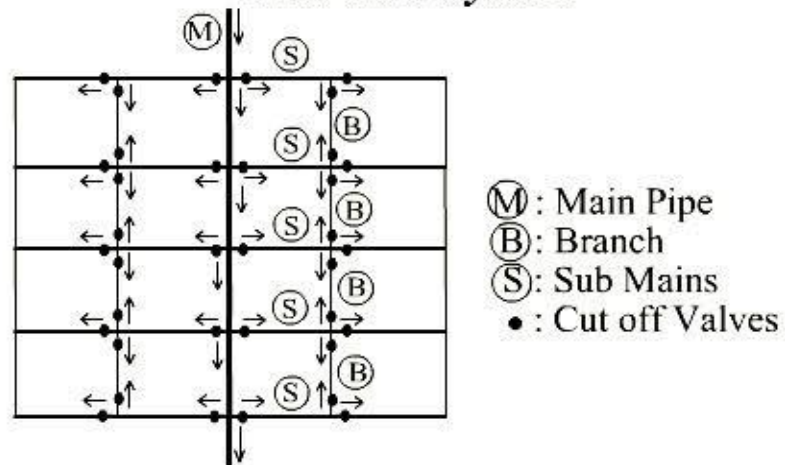
### Disadvantages:

1. If any damage occurs – supply is going to be stopped.
2. More no. of dead ends – prevent free circulation of water – reduces quality – scour valve to remove stagnant water periodically.
3. Discharge from one direction – fire accidents – no adequate supply of water.

### 2. Grid iron system:

- Mains, sub-mains and branches are interconnected with each other.
- A well planned city roads are planned like this – so pipe lines can follow easily.
- Principle of grid end can be applied to tree system also by closing the loop – removing the dead ends.

## Grid-iron System



**Fig: Grid Iron System**

### Advantages:

- Friction losses are less, size of pipe
- Even at repairs – small area is avoided.
- Because of inter-connection – dead ends are eliminated – so free circulation of water will be there.
- During fire accidents – more water can be conveyed.

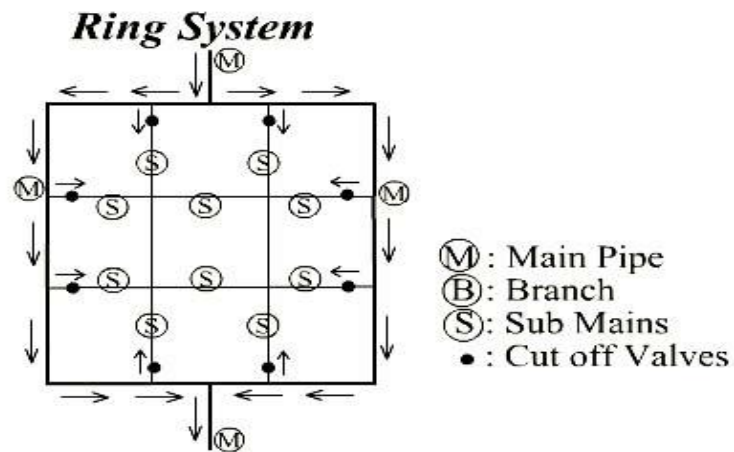
### Disadvantages:

- More length of pipes required – more sluice valves also
- Construction is costlier
- Design is difficult and costlier.

### 3. Ring System:

This system is also sometimes called Circular system. In this system a closed ring, either circular or rectangular of the main pipes, is formed around the area to be served as shown in Fig. The distribution area is divided into rectangular or circular blocks and the main water pipes are laid on the periphery of these blocks. The sub--mains periphery may be placed as shown. The ring system is very suitable for towns and cities having well planned roads. Sometimes, this system is used as a looped feeder placed centrally around a high demand area along with the grid iron system. In such a case, this enhances the capacity of the grid iron system and will improve the pressures at various points. Advantages and disadvantages are same as grid iron system.

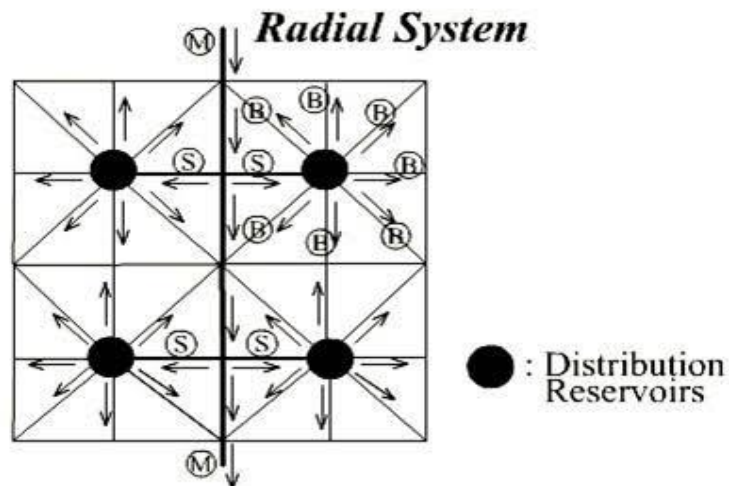




**Fig: Ring System**

**4. Radial System:**

If a city or a town is having a system of radial roads emerging from different centres, the pipe lines can be best laid in a radial method by placing the distribution reservoirs at these centres. In this system, water, is therefore, taken from the water mains, and pumped into the distribution reservoirs placed at different centres, as shown in Fig. The water is then supplied through radially laid distribution pipes. This method ensures high pressures and efficient water distribution. The calculations for design of sizes are also simple.



**Fig: Radial System**

## DESIGN OF PIPE NETWORKS:

- Depending upon the various factors, such as relative levels of the different zones of the city, the layout of the roads etc., the type of distribution network to be adopted is decided first.
- After the layout plan of the distribution pipes and the locations of other appurtenances is finalised, the sizes of the pipes are computed.
- No direct method is available to compute the pipe sizes of a distribution network, hence trial procedure is adopted.
- Sizes are assumed and terminal pressures are computed to compare them with the designed minimum and maximum pressures.
- If the required matching is not obtained, then the sizes are changed and the procedure is repeated till the required matching is obtained.
- To find the terminal pressures in all the pipes, the head loss through each pipe is need to be evaluated.
- The head loss in a pipe is easily calculated by Darcy weisbatch or Hazen William formula. Head loss can be computed, if the discharges flowing through the different pipes are known.
- Neglecting minor losses, frictional head loss ( $H_L$ ) is given by Hazen William's formula is thus considered to be equal to the total head loss in the pipe. The loss is given by equation.,

$$V = 0.85 C_H R^{0.63} S^{0.54}$$

$$\text{Where } S = \frac{H_L}{L}$$

$$H_L = \frac{1}{0.094} \frac{L}{d^{4.87}} \left( \frac{Q}{C_H} \right)^{1.85}$$

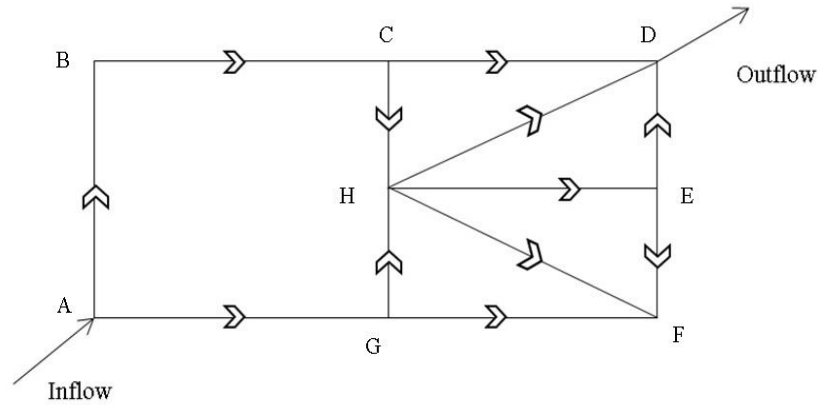
Where  $R$  = Hydraulic radius or Hydraulic mean depth =  $A/P$

$S$  = friction slope

$d$  = Internal diameter

## PIPE NETWORKS

A group of interconnected pipes forming several loops as shown in fig below is called a network of pipes. Such networks of pipes are commonly used for municipal water distribution systems in cities.



The main problem in a pipe network is to determine the distribution of flow through the various pipes of the network such that all the conditions of flow are satisfied and all the circuits are then balanced. The conditions to be satisfied in any network of pipes are as follows:

1. According to the principle of continuity the flow into each junction must be equal to the flow out of the junction. For example at junction A, the inflow must be equal to the flow through AB and AG.
2. In each loop, the loss of head due to flow in clockwise direction must be equal to the loss of head due to flow in anticlockwise direction. For example in the loop ABCHG the sum of the head losses due to flow in AB, BC and CH (clockwise flow) must be equal to the sum of the head losses due to flow in AG and GH (anticlockwise flow).
3. The Darcy-Weisbach equation must be satisfied for flow in each pipe. Minor losses may be neglected if the pipe lengths are large. However if the minor losses are large, they may be taken into account by considering them in terms of the head loss due to friction in equivalent pipe lengths. According to Darcy-Weisbach equation the loss of head  $h_f$  through any pipe discharging at the rate of Q can be expressed as

$$h_f = rQ^n$$

Where  $r$  is a proportionality factor which can be determined for each pipe knowing the friction factors  $f$ , the length  $L$  and the diameter  $D$  of the pipe  $\left( r = \frac{fL}{2g(\pi/4)^2 D^5} = \frac{fL}{12.10D^5} \right)$ ; and  $n$  is an exponent having numerical value ranging from 1.72 to 2.00.

## HARDY – CROSS METHOD

The pipe network problems are in general complicated and cannot be solved analytically. As such methods of successive approximations are utilised. One such method which is commonly used is ‘Hardy Cross Method’, named after its original investigator. The procedure for the solution of pipe network problems by the Hardy Cross Method is as follows:

- (1) Assume a most suitable distribution of flow that satisfies continuity at each junction.
- (2) With the assumed values of  $Q$ , compute the head losses for each pipe using  $h_f = rQ^n$
- (3) Consider different loops or circuits and compute the net head loss around each circuit considering the head loss in clockwise flows as positive and in anti-clockwise flows as negative. For a correct distribution of flow the net head loss around each circuit should be equal to zero, so that the circuit will be balanced. However, in most of the cases, for the assumed distribution of flow the head loss around the circuit will not be equal to zero. The assumed flows are then corrected by introducing a correction  $\Delta Q$  for the flows, till the circuit is balanced. The value of the correction  $\Delta Q$  to be applied to the assumed flows of the circuit may be obtained as follows:

$$\Delta Q = - \frac{\sum rQ_0^n}{\sum rnQ_0^{n-1}}$$

In the above expression for the correction the denominator is the sum of absolute terms and hence it has no sign. Further if the head losses due to flow in the clockwise direction are more than losses due to flow in the anti-clockwise direction, then according to the sign convention adopted,  $\Delta Q$  will be negative and hence it should be added to the flow in the anti-clockwise direction and subtracted from the flow in the clockwise direction. On the other hand if the head losses due to flow in the clockwise direction are less than the head losses due to flow in the anti-clockwise direction, then  $\Delta Q$  will be positive hence it should be added to the flow in the clockwise direction and subtracted from the flow in the anti-clockwise direction. Moreover, for the pipes common to two circuits or loops (such as CH, GH, HF etc.) a correction from both the loops will be required to be applied.

- (4) With the corrected flows in all the pipes, a second trial calculation is made for all the loops and the process is repeated till the correction become negligible.

## EQUIVALENT PIPE

Often a compound pipe consisting of several pipes of varying diameters and lengths is to be replaced by a pipe of uniform diameter, which is known as *equivalent pipe*. The uniform diameter of the equivalent pipe is known as the equivalent diameter of the compound pipe. The size of the equivalent pipe may be determined as follows.

If  $L_1, L_2, L_3$  etc., are the lengths and  $D_1, D_2$  and  $D_3$  etc., are the diameters respectively of the different pipes of a compound pipeline, then the total head loss in the compound pipe, neglecting the minor losses, is

$$h_L = \frac{f_1 L_1 V_1^2}{2gD_1} + \frac{f_2 L_2 V_2^2}{2gD_2} + \frac{f_3 L_3 V_3^2}{2gD_3} + \dots$$

Again by continuity

$$\begin{aligned} Q &= a_1 V_1 = a_2 V_2 = a_3 V_3 \\ &= \frac{\pi}{4} D_1^2 V_1 = \frac{\pi}{4} D_2^2 V_2 = \frac{\pi}{4} D_3^2 V_3 = \dots \end{aligned}$$

Assuming

$$\begin{aligned} f_1 &= f_2 = f_3 = \dots = f \\ h_L &= \frac{f}{2g} \frac{Q^2}{(\pi/4)^2} \left[ \frac{L_1}{D_1^5} + \frac{L_2}{D_2^5} + \frac{L_3}{D_3^5} + \dots \right] \end{aligned}$$

If  $D$  is the diameter and  $L$  is the length of the equivalent pipe then it would carry the same discharge  $Q$  if the head loss due to friction in the equivalent pipe is same as that in the compound pipe. The loss of head due to friction in the equivalent pipe is

$$h_L = \frac{fLV^2}{2gD} = \frac{f}{2g} \frac{Q^2}{(\pi/4)^2} \frac{L}{D^5}$$

Thus equating the two heads losses, we get

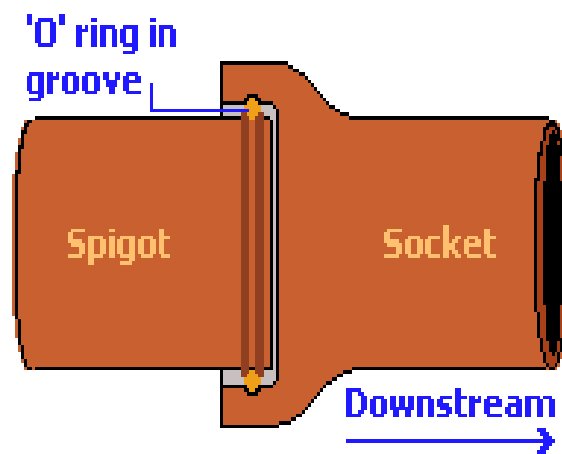
$$\frac{L}{D^5} = \left[ \frac{L_1}{D_1^5} + \frac{L_2}{D_2^5} + \frac{L_3}{D_3^5} + \dots \right]$$

The above equation is known as *Dupuit's equation*, which may be used to determine the size of the equivalent pipe. Thus if the length of the equivalent pipe is equal to the total length of the compound pipe i.e.,  $L = (L_1, L_2, L_3 + \dots)$ , then the diameter  $D$  of the equivalent pipe may be determined by using above expression.

## PIPE JOINTS:

### 1. Socket and Spigot joint:

- Cast iron pipes are being joined by a socket and spigot joint (sometimes called as bell and spigot joint).
- The cast iron pipes which are to be joined by the socket and spigot Joint are made in such a way that one of their end is enlarged, whereas the other end is normal. The enlarged end is called socket or bell, while the normal end is called Spigot.
- The spigot is fitted into the socket. A few strands of jute are wrapped around the spigot before inserting it into the socket (or bell) and then, more jute is packed into the joint.
- The remaining space between the socket and the spigot is finally filled with molten lead.
- The quantity of lead required per joint varies from 3.5 to 4 kg for 15 cm dia. pipe, to about 45 to 50 kg for 1.2 metre dia. pipe.
- This type of joint is somewhat flexible and allows the pipes to be laid on flat curves without the use of specials. However, skilled labour is required for this type of joints.

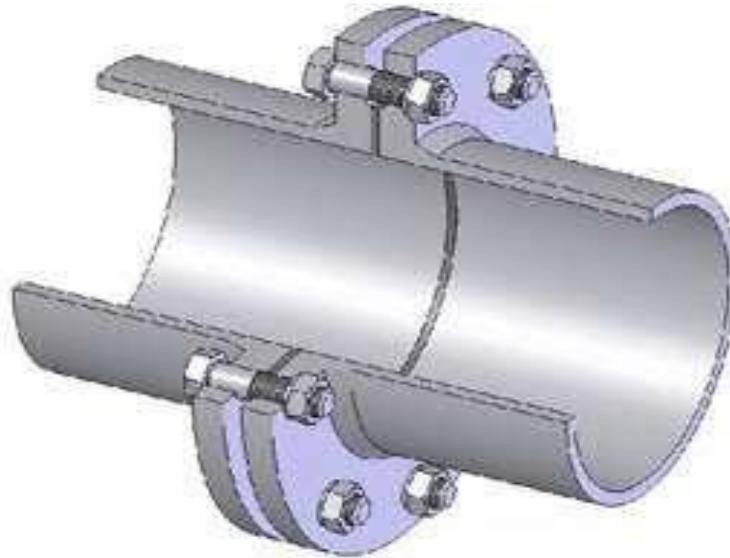


**Fig: Spigot and Socket Joint**

### 2. Flanged joint:

- Flanged joints are used for pumping stations, filter plants and at other locations where it may be necessary to occasionally disjoint the pipe. Cast iron pipe lengths to be joined by this.

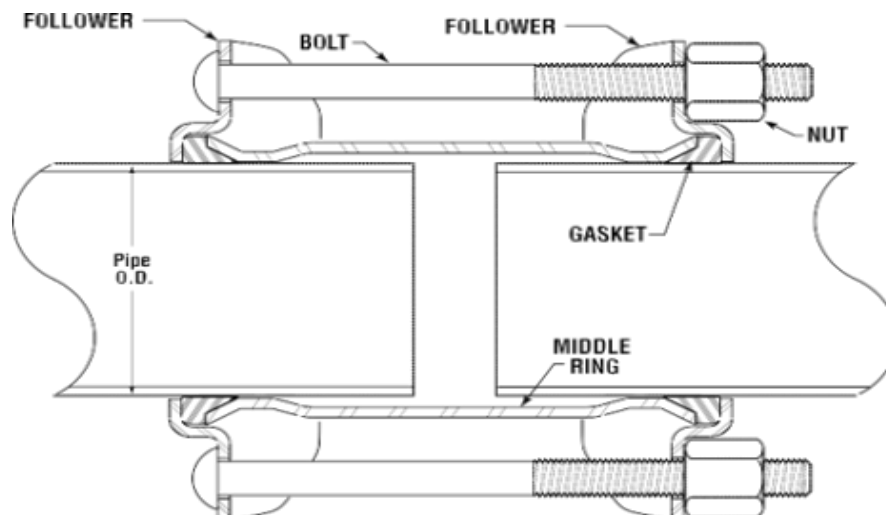
- Two flanges are brought together keeping a rubber washer (called gasket) in between them, so as to make them water tight. They are fixed by means of nuts and bolts.
- These joints are strong but rigid and hence cannot be used where deflections or vibrations are expected. They are expensive and mostly used for indoor works (such as in pumping stations, filter plants etc.)



**Fig: Flanged Joint**

### **3. Mechanical joint or dresser coupling:**

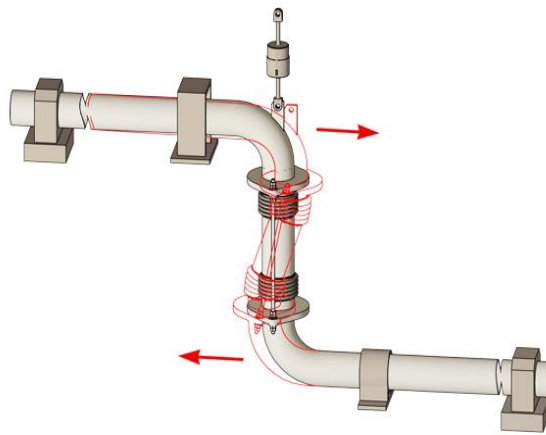
- Used to join the plain ends of cast iron pipes.
- Special type of metallic collar is fitted and tightened over the abutting ends, thus forming a mechanical joint.
- These joints are strong and rigid.
- They can withstand vibrations.



**Fig: Mechanical joint**

**4. Flexible joint:**

- Used where large scale flexibilities are required. (Used on the river beds).
- The pipes to be provided with such a joint are cast with special type of ends. The socket is spherical and the spigot through plain is having a bead at the end.
- A retainer ring is placed over the bead which keeps the special rubber gasket in position.
- A split cast iron gland ring is then placed over it, tightened by means of bolts and nuts.



**Fig: Flexible joint**

**5. Expansion joint:**

- Expansion joints are provided at suitable intervals in the pipe lines, so as to counteract the thermal stresses produced due to temperature variations.
- For providing expansion joints in cast iron pipes, the socket end is cast flanged and the spigot end is plain. The socket end is connected rigidly to an annular ring which can slide freely over the spigot end.
- While making this joint, a small space (equal to  $L \alpha T$ ) is kept between the face of the spigot and the inner face of the socket and the spigot is filled up by means of a rubber gasket.
- The flanges are then tightened by means of nuts and bolts.
- When the pipes expand, the socket-end moves forward and the gap left (equal to  $L \alpha L$ ) just gets closed. Similarly, when the pipes contract the socket moves



backward creating the gap. All the time, the annular ring follows the movements of the socket and maintains the gasket in position, thus keeping the joint watertight.

## VALVES:

### 1. Sluice valves or Gate valves:

- Are used to regulate the flow through pipes.
- Valves are fixed at every 3 to 5 km intervals on the pipe line dividing it to different sections.
- By closing the two valves at ends, for carrying out repairs in that section.
- Are also placed at street corners or where two pipe lines intersect.
- Are usually placed at points of low pressures.
- Are cheap and offers less resistance to flow of water when the valve is wide open.
- Similar to gate valves used in dams but are not so large and also known as shut off valves or stop valves.

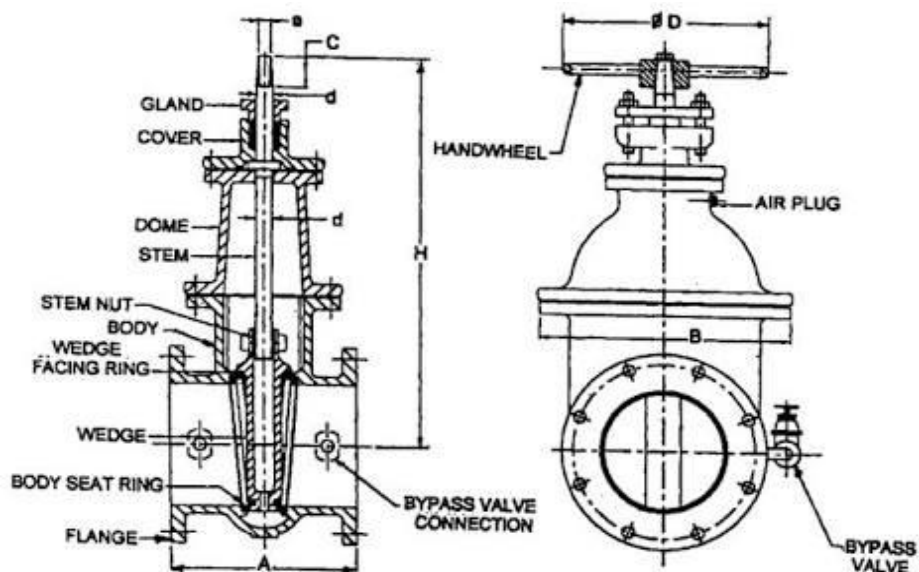


Fig: Sluice Valve

### 2. Air Valves:

- Are the special kind of valves, generally placed along the pipe line at summits on both sides of sluice valves and also on the downstream side of all other sluice valves.
- When supply is restored and pipe is refilled after repairs, air gets accumulate at high points may obstruct the free flow of water and pipe may get air locked.

- Valves are therefore provided at summits to remove the accumulated air known as air-relief valves
- When during steady flow the valve 'A' is suddenly closed vacuum gets created downstream of 'A'.
- Valves placed are opened out automatically and allowing outside air to enter into the pipe lines.
- So that development of negative pressures can be avoided in the pipe lines.
- Such a valve, thus protect pipe against collapse called air inlet valve.



**Fig: Air Valve**

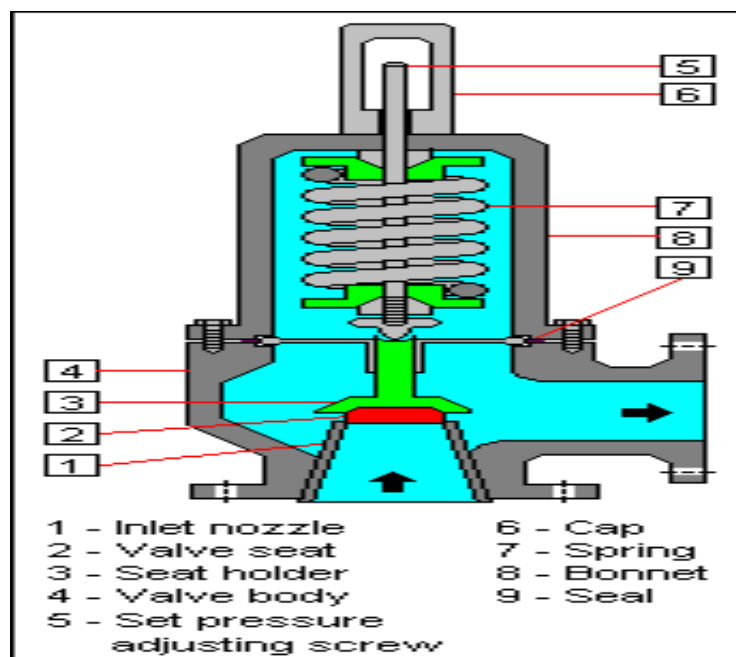
### **3. Blow off valves or drain valves or scour valves:**

- In order to remove the entire water from within a pipe (after closing the supply), small gated off-takes are provided at low points. These valves are known as blow off valves or drain valves or scour values.
- These valves are necessary at low level points for completely emptying the pipe for inspection, repairs, etc.
- When opened, water comes out of these valves quickly under gravity and they are made to discharge water into some natural drainage channel or into a sump from which the water can be pumped out.
- It may, however, be stressed that there should be no direct connection between the valve and the sewer or drain, so as to avoid the possibility of pollution travelling into the water pipe.

- For safety, two drain valves are generally placed in series, so as to reduce the chances of such pollution reaching the water in the conduit.

#### 4. Pressure relief valves:

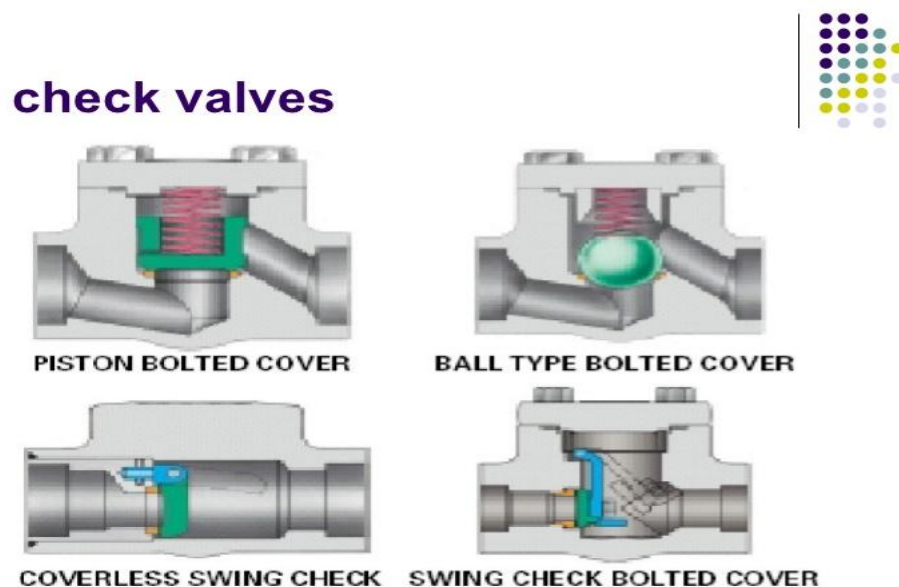
- Water hammer pressures in pressure pipes can be reduced by using pressure relief valves. Such a valve is adjusted to open out automatically as soon as the pressure in the pipe exceeds a certain fixed-predetermined value.
- Due to the opening of this valve, certain water will get out we pipe, and thus, reducing the pressure in the pipe. As soon as the water hammer pressure reduces, and the pressure in the pipe falls up to the fixed value, the valve will close automatically.
- Such type of valves are useful on small pipelines, where the escape of a relatively smaller amount of water will alleviate water hammer pressures.
- A simple sketch of a pressure relief valve is shown in Fig. Since the positive water hammer pressure is developed due to the sudden closure of a sluice valve, on its upstream side, such relief valves may be provided on the upstream side of the sluice valves.
- Even if not provided specifically for water hammer, such valves are often placed along the pipe line at suitable intervals, so as to function during emergencies, when pressure rises in the pipe above the design value, and thus to help in protecting the pipe joints from getting loosened or the pipes from getting burst.



**Fig: Pressure Relief Valve**

## 5. Check Valves:

- Check valves are sometimes called as non-return valves because they prevent water to flow back in opposite direction.
- May be installed on the delivery side of the pumping set, so as to prevent the back flow of stored or pumped water, when the pump is stopped.
- Are also installed on pump discharges to reduce water hammer forces on the pump.
- Such a valve may be a simple swing check or ball devices, in small lines, but in large installations they should be designed to close slowly, usually with discharge of some water through a bypass.
- Check valves are also required at inter-connections between polluted water system and potable water system. So as to prevent the entry of pollution into the pure water.
- A check valve installed at the end of a suction line is called a foot valve and prevents draining of the suction when the pump stops.



**Fig: Check Valves**